

# TOMCAT®

# XR

## 34" - 46" Scrubbers



SCRUBBERS      SWEEPERS      BURNISHERS      CARPET CARE      FLOOR MACHINES



# KEY FEATURES

# APPLICATIONS



**Machine Control Panel** uses off-the-shelf toggle and marine duty switches and features universal icons which simplifies training.



**Vacuum Muffler** allows machine to consistently achieve as low as 67 dB while thoroughly drying the floor.



**Squeegee Adjustments made simple** with quick change squeegee latch allows toolless maintenance and 4-sided squeegee blade.

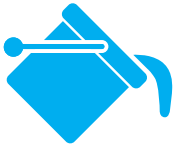

**Fill System** features a recessed trough with removeable stainless screen for easy bucket filling as well as a hose lock notch.



**Oversized Vacuum Screen Shut-Off** quickly arrests overflow issues to protect the Vacuum Motor.

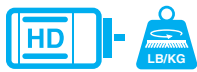

**High Performance motors and down pressure** provides an unmatched standard of cleaning.



- School Systems
- Sports Arenas
- Retail
- Food & Beverage
- Healthcare
- Grocery Stores
- Automotive
- Airports

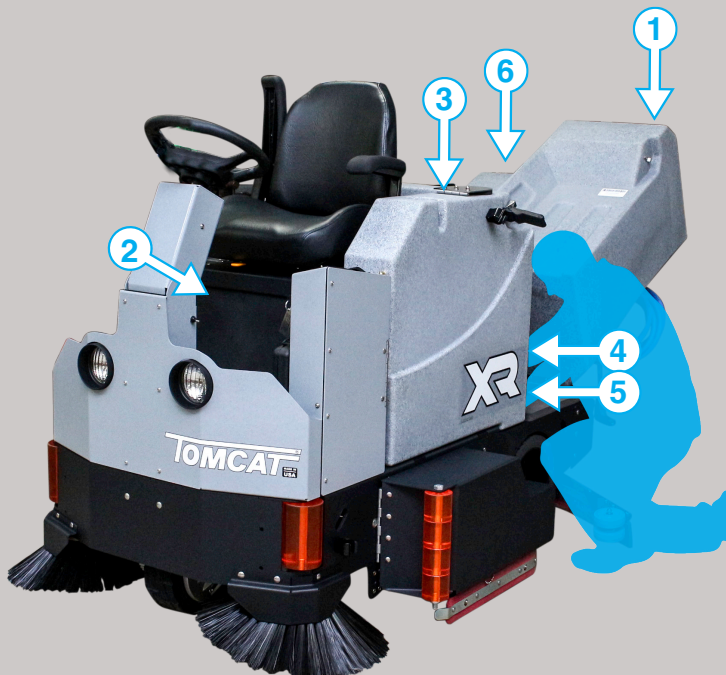

## TANK TIPS FOR ACCESS

- 1 Vacuum Screen Cleaning
- 2 Service Batteries
- 3 Solution Fill Screen
- 4 Inspect Vacuum Motors
- 5 Inline Solution Filter
- 6 Drain Saver

Reduce costly repairs associated with clogged floor drains with our Drain Saver Basket.



# VIEW INSIDE

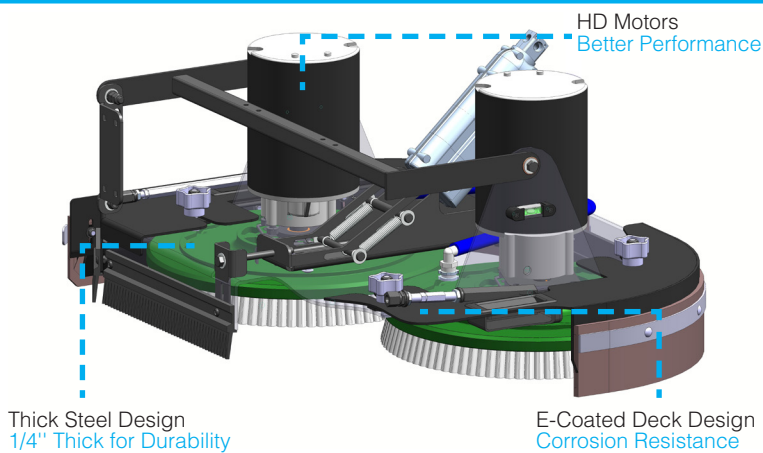
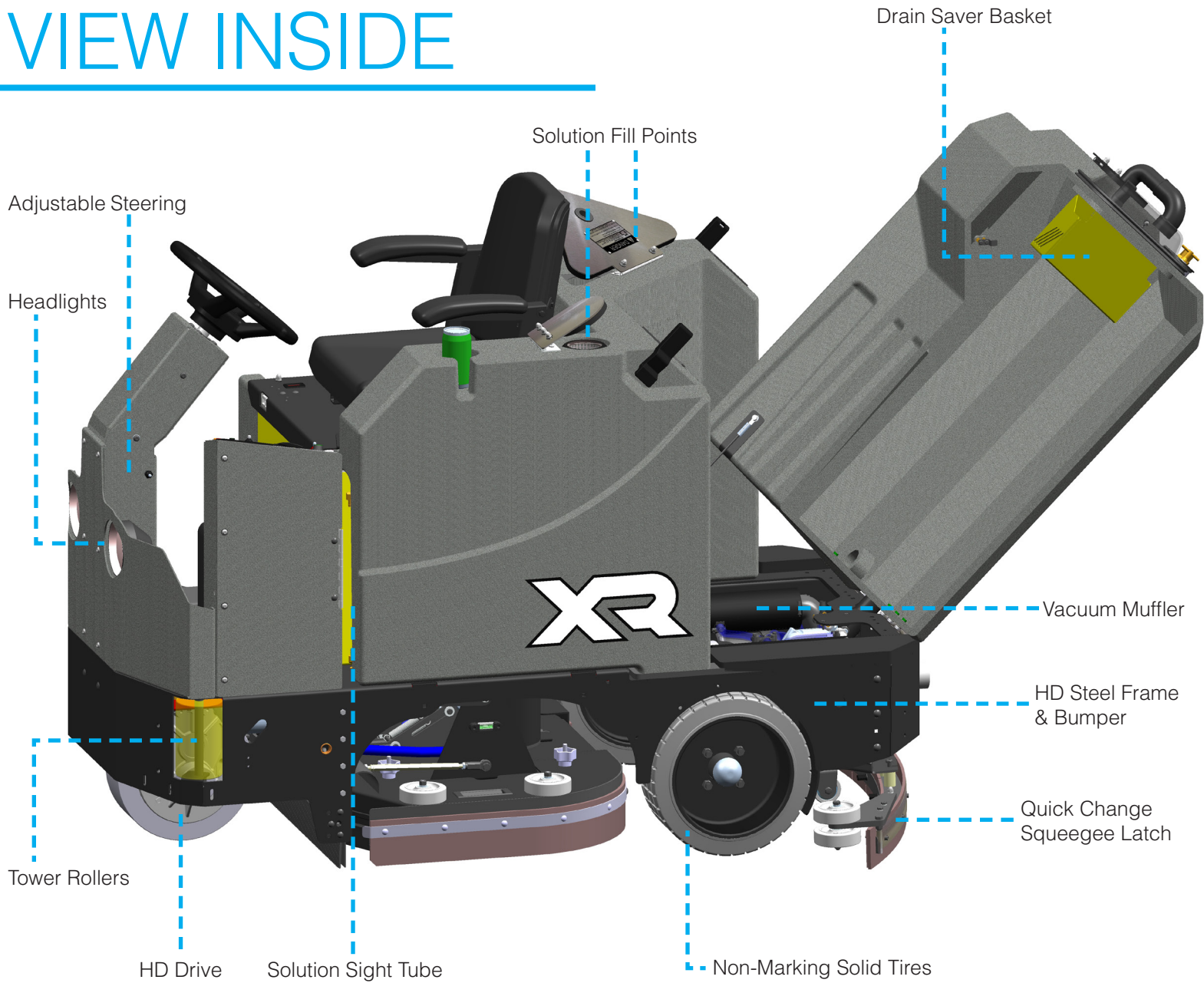

## Disk Benefits

- Brush / Pad Selection
- Lowest Maintenance Cost
- Gimballled Drivers Improves Cleaning On Irregular Floors
- Brushes Individually Driven For Unmatched Performance

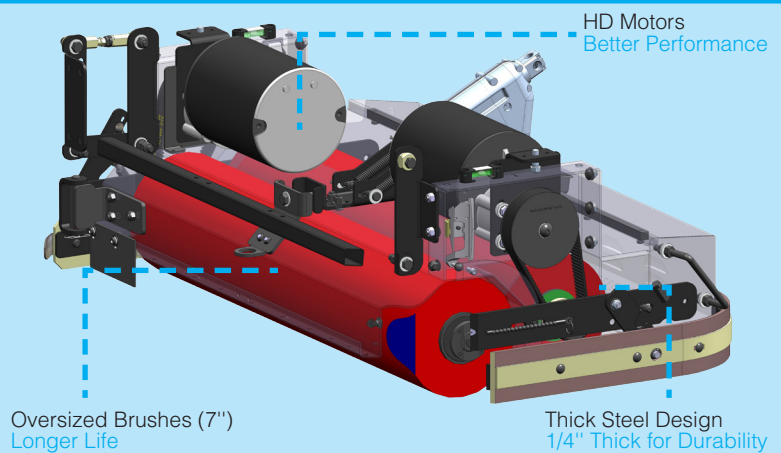

## Cylindrical Benefits

- Eliminates Dust Mopping
- Scrub & Sweep Simultaneously
- Superior Tile & Grout Cleaning

# CALL FOR A DEMONSTRATION



☎ 800-450-9824

🌐 (+001)-262-681-6470

🌐 [www.tomcatequip.com](http://www.tomcatequip.com)

Since 1986, our family owned company has been designing, building and supporting the best in floor maintenance equipment. Our **TOMCAT** brand services the world with unsurpassed commercial cleaning equipment, continually exceeding expectations and setting the industry bar that much higher.

We've built our reputation by providing the highest value machines and providing local support via 425 distributors in over 42 different countries.

## AUTHORIZED DISTRIBUTOR

### BODY CONSTRUCTION / DIMENSIONS

Tank Material:	Poly 3/8" (9.5 mm)
Chassis Construction:	3/16" Steel (4.8 mm) Powder Coated Steel
Front Wheel (Diameter x Width):	12" x 4" (30.5 x 10.2 cm) - Solid Black
Rear Wheels (Diameter x Width):	(2x) 14" x 5" ((2x) 35.6 x 12.7 cm) - Solid Black
Size (L x W x H):	69" x 36" x 56" (175.3 x 91.4 x 142.2 cm)
Weight (w/o Batteries):	1,200 - 1,250 lbs (544 - 567 kg)
Weight (w/ 325 ah Batteries):	1,925 - 1,975 lbs (873 - 896 kg)

### BRUSH / PAD SYSTEM

Disk Dimensions:	34" - (2x) 17" Diameter (86.4 - [2x] 43.2 cm)
45 Inch Deck Includes HD Side Doors	40" - (2x) 20" Diameter (101.6 - [2x] 50.8 cm)
	45" - (2x) 23" Diameter (114.3 - [2x] 58.4 cm)
Disk Motor:	(2x) 1.0 hp ((2x) 746 watts)
Disk Brush Speed:	200 rpm
Cylindrical Dimensions:	34" - (2x) 7" x 32" (86.4 - [2x] 17.8 x 81.3 cm)
7" Diameter Brush	40" - (2x) 7" x 38" (101.6 - [2x] 17.8 x 96.5 cm)
46 Inch Deck Includes HD Side Doors	46" - (2x) 7" x 44" (116.8 - [2x] 17.8 x 111.8 cm)
Cylindrical Motor:	(2x) 1.5 hp / 350 rpm ((2x) 1,119 watts)
Cylindrical Brush Speed:	750 rpm
Brush Pressure Settings:	(5) with Auto Adjust
Brush Down Pressure:	Up to 250 lbs (113 kg) / 500 lbs (227 kg) Actuator Rating

### POWER SYSTEM

System Voltage:	36 VDC
Standard Battery:	325 ah WET
Optional Battery:	425 ah WET / 440 ah Industrial / 400 ah AGM
Run Time:	Up to 5.0 Hours*
*Run times are based on continuous scrubbing run times.	
Charger:	120VAC / 60 Hz Input - 36VDC / 30 amp Output

### DRIVE SYSTEM

Power:	3.0 hp - All Gear / Sealed (2,237 watts)
Forward Speed:	0 - 320 ft/min / 0 - 3.6 mph (0 - 98 m/min / 0 - 6 km/h)
Scrubbing Speed:	0 - 256 ft/min / 0 - 2.9 mph (0 - 78 m/min / 0 - 5 km/h)
Reverse Speed:	0 - 230 ft/min / 0 - 2.6 mph (0 - 70 m/min / 0 - 4 km/h)

### SOLUTION / RECOVERY SYSTEMS

Solution Tank Capacity:	65 Gallons (246.1 liters) - w/ Graduated Site Tube
Solution Flow / Filter:	0 - 1.0 GPM / Stainless Inline (0 - 3.7 LPM)
Recovery Tank Capacity:	78 Gallons (295.3 liters) - 2" (5.08 cm) diameter Drain Hose
Demisting Chamber:	1.25 Gallons (4.7 liters)
Drain Saver:	30 cubic inches (492 cubic cm)
Vacuum Power:	(2x) 1.0 hp / 3 Stage (740 watts)
Vacuum Specs (Water Lift / Airflow):	70" / 140 cfm (177.8 cm / 4 cm/m)
Squeegee:	Curved w/ 4-sided Rear Blade & Quick Change Latch
	34D & 34C - 46" (116.8 cm)
	40D & 40C - 53" (134.6 cm)
	45D & 46C - 60" (152.4 cm)

### GENERAL

Cleaning Width:	34", 40", & 45" - Disk (86.4, 101.6, 114.3 cm)
	34", 40", & 46" - Cylindrical (86.4, 101.6, 116.8 cm)
Decibels:	67 dB
Productivity - Theoretical:	Up to 49,587 sqft (4,607 sqm)**
**Productivity is based off of ISSA 2010 Cleaning Times	
Productivity - Practical:	Up to 22,989 sqft (2,136 sqm)**
**Productivity is based off of ISSA 2010 Cleaning Times	



**Manufactured By**  
 R.P.S. Corporation  
 1711 South Street  
 Racine, Wisconsin 53404 (USA)  
 Phone: (800) 450-9824  
 International: (+001) 262-681-6470  
[www.tomcatequip.com](http://www.tomcatequip.com)